

Specifications

Nominal Voltage Nominal	6v
Capacity (20 Hr)	225AH
Length	260mm
Width	180mm
Height	247mm
Total Height	253mm
Weight	30.5Kg
Max Discharge Current	-A (5 Sec)
Container Material	ABS resin
Internal Resistance	-mΩ
Initial Charging Current	Less than -A
Rated Capacity (+/- 5%)	224 AH (20h, 1.75V/cell, 25°C/77°F) 210 AH (10hr, 1.75V/cell, 25°C/77°F) 192 AH (5hr, 1.75V/cell, 25°C/77°F)
Operating temperature range	
Charge:	0~40°C (32~104°F)
Discharge:	-15~50°C (5~122°F)
Storage:	-15~40°C (5~104°F)
Charge retention (shelf life) at 20°C (68°F)	
1 month	97%
3 months	91%
6 months	85%

Dimensions

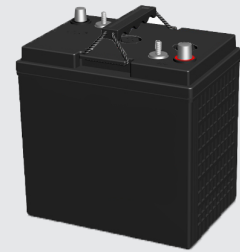
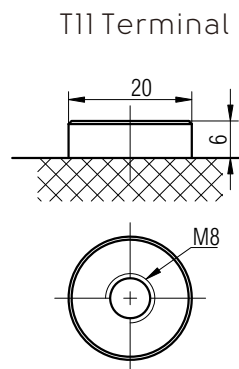
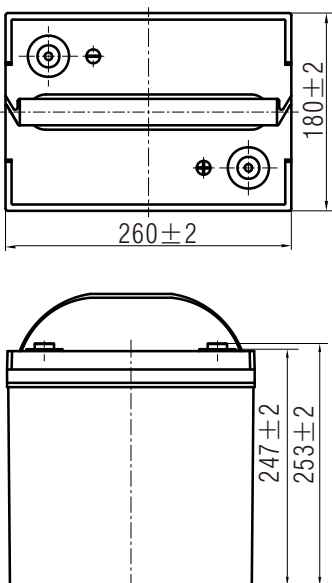

FEATURES

- Deep cycle AGM technology
- Plus carbon technology
- Lead calcium grids for extended life.

Sealed Construction

Sterling's unique construction and sealing technique ensures no electrolyte leakage from case or terminals.

Electrolyte Suspension System

All HPC series batteries utilise Sterling's unique electrolyte suspension system incorporating a microfiber glass mat to retain the maximum amount of electrolyte in the cells. The electrolyte is retained in the separator material and there is no free electrolyte to escape from the cells.

Control of Gas Generation

The design of HPC series batteries incorporates the very latest oxygen recombination technology to effectively control the generation of gas during normal use.

Terminals

Sterling's HPC series batteries are manufactured using a range of terminals which vary in size and type. Please see diagram opposite.

Valve Regulated Design

The batteries are equipped with a simple, safe low pressure venting system which releases excess gas and automatically reseals should there be a build up of gas within the battery due to severe overcharge. Note. On no account should the battery be charged in a sealed container.

Charging and Discharging Information

LEOCH LDC AGM Charging Profile

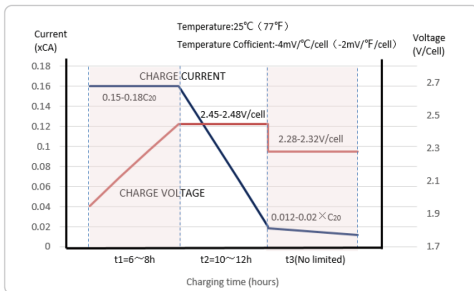

Cycle life in relation to Depth Of Discharge

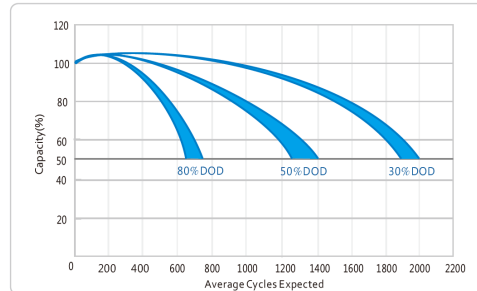

Self-discharge Characteristic

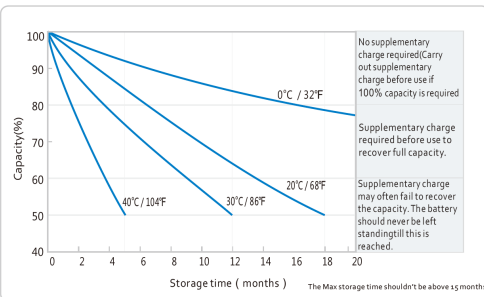

Relationship of OCV and State Of Charge (25°C, 77°F)

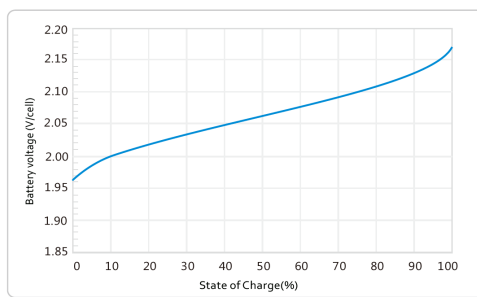

Charging (25°C/77°F)

Standby use: Float charging voltage 6.75V to 6.9V. (Temperature compensation recommended)

Cyclic use: maximum charging current (see front page). Charging voltage 7.2V - 7.5V.

Top charge: Product in storage (ambient temperature) required a top charge every 6 months at 25°C (77°F). For higher temperatures, time intervals will be shorter.

Discharge

Stop operation when voltage has reached the minimum permissible voltage; recharge immediately.

Storage

Always store battery in fully charged condition.

Store batteries in a dry and cool location.

Temperature

For standby use, batteries should be kept in an ambient temperature of 25°C.

Caution

- Do not short circuit
- Do not charge in a sealed container
- Service life and operational characteristics will be effected by temperature
- AC ripple reduces service life



For any further technical information please call the head office.

Applications

- Renewable Energy • Marine • Uninterruptible Power Supply (UPS) • Electric Power System (EPS) • Emergency Lighting
- Railway/Aircraft Signal • Alarm & Security System • Electronic Equipment • Communication Power Supply
- DC Power Supply